

ALARM BUTTON FOR OUTDOOR

AE/V-PSIP

Description

Conventional alarm button indicated for outdoor use, IP66 according to EN 54-11 standard. It has a microswitch with a 470 ohm or 680 ohm load resistance, a verification system with a reset key and an alarm led. It allows the mounting of calibrated plastic sheet so that it is locked and does not break or of breakable glass - both supplied.

CE certified according to CPD. LPCB certificate.



Dimensions

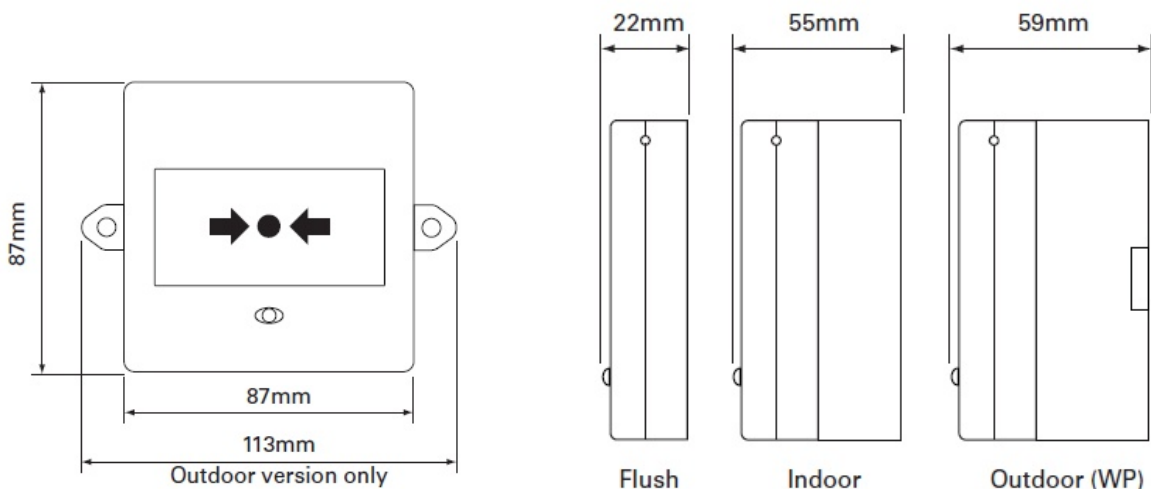

TECHNICAL CHARACTERISTICS

Voltage:	Up to 30Vdc
Resistance:	470/680
Material types:	glass / plastic (resettable)
Temperature:	-25°C to + 70°C
Protection:	IP66
Material:	ABS
Weight:	0.22 Kg
Color:	Red